

# Wall & Ceiling Board Installation Guide

# Trusscore Wall&CeilingBoard

Trusscore Wall&CeilingBoard is designed with a high-strength polymer formulation and engineered to be the perfect alternative to traditional drywall systems or fiberglass reinforced panels (FRP). The Trusscore tongue and groove interlocking system makes installation quick and easy, and the unique truss design provides industry leading strength and durability.

Where you need a smooth finish that is easy to clean, low-maintenance, and abuse-resistant, Trusscore Wall&CeilingBoard has your project covered.

## Contents

<a href="#">Warranty</a>	2
<a href="#">Tools Required</a>	3
<a href="#">General Recommendations</a>	3
<a href="#">Temperature Range</a>	3
<a href="#">Cutting Panels</a>	3
<a href="#">Ripping Panels</a>	4
<a href="#">Cutouts</a>	4
<a href="#">Fastening</a>	4
<a href="#">Panel Spacing</a>	5
<a href="#">High-Moisture Environments</a>	5
<a href="#">Use of Silicone Sealant</a>	5
<a href="#">Radiant Heat</a>	6
<a href="#">Epoxy Floors</a>	6
<a href="#">CFIA, USDA &amp; FDA Approved Installations</a>	6
<a href="#">Planning &amp; Preparation</a>	6
<a href="#">Acclimatizing Your Product</a>	6
<a href="#">Planning Your Installation</a>	6
<a href="#">Installation Order</a>	7
<a href="#">Ceiling Installation</a>	7
<a href="#">Drywall Grid Ceiling Installation</a>	8
<a href="#">Wall Installation</a>	8
<a href="#">Vertical Panels</a>	8
<a href="#">Horizontal Panels</a>	9
<a href="#">Integrating Trusscore SlatWall with Trusscore Wall&amp;CeilingBoard</a>	9
<a href="#">Placement and Layout of Installation Area</a>	10
<a href="#">Bottom Connection</a>	11
<a href="#">Side Connection</a>	12
<a href="#">Top Connection</a>	14
<a href="#">Trim Applications</a>	15
<a href="#">Installation Tips</a>	15
<a href="#">Inside Corners</a>	15
<a href="#">Outside Corners</a>	17
<a href="#">Bottom of Wall</a>	18
<a href="#">Top of Wall</a>	19
<a href="#">Ceiling Perimeter</a>	20
<a href="#">Panel Joints</a>	21
<a href="#">Window &amp; Door Openings</a>	21
<a href="#">How to Replace a Damaged Panel After Installation</a>	22
<a href="#">Cleaning</a>	23
<a href="#">Day-to-Day Cleaning</a>	23
<a href="#">Pressure Washing</a>	23
<a href="#">Disclaimers</a>	23
<a href="#">Specifications</a>	24
<a href="#">Trim Dimensions</a>	25

## Warranty

For more information on product warranty please visit [trusscore.com/warranty](https://trusscore.com/warranty)

# Congratulations on your decision to use Trusscore Wall&CeilingBoard!

Your project will soon look amazing, and it will last a lifetime. If you've never installed Trusscore products before, or even if you've installed Trusscore in the past, be sure to familiarize yourself with this guide. It's filled with tips, time-saving suggestions, and a few must-do's that will make your installation successful.

Let's get started.

## Tools Required



Drill/Screw Gun



Level



Safety Glasses



Radial Arm Saw or Handheld Power Saw



Putty Knife



Face Mask



Tin Snips



Utility Knife



Tape Measure



Ladder and/or Scaffolding

## General Recommendations

### Temperature Range

Trusscore Wall&CeilingBoard is designed to be installed between 10-20°C (50-68°F). For installations outside that temperature range, please consult our [Cold Weather Installation Guide](#).

### Cutting Panels

As a simple method of eliminating cracking or chipping Trusscore Wall&CeilingBoard, the use of a concrete/masonry blade when cutting Wall&CeilingBoard panels is recommended. Alternatively, a fine-tooth blade (12 to 16 teeth per inch) installed in the reverse direction can be used.

In cold weather, move the saw through the material slowly to prevent chipping or cracking (Fig. 1). Performing a test cut will allow you to confirm the performance of your cutting tool without impacting your project.

For your safety, safety goggles and a face mask should be worn while using a power saw.

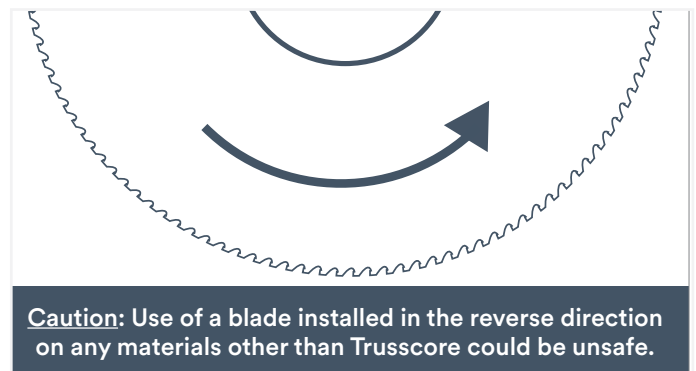



Fig. 1

**Caution:** Use of a blade installed in the reverse direction on any materials other than Trusscore could be unsafe.

 Any offcuts you create are recyclable.

## Ripping Panels

A rip-cut is a technique (common in woodworking) that cuts a material in a straight line, parallel to the length of the board/panel. Cutting Trusscore Wall&CeilingBoard with this technique is occasionally necessary, depending on the layout and configuration of the project.

To ensure even panel spacing on your project, plan the layout of your Wall&CeilingBoard panels prior to installation. If the wall space requires performing a rip cut on one or more panels, ensure that any ripped panels maintain a minimum width of 8". If necessary, cutting both the first panel and last panel of your wall or ceiling installation will accomplish this.

- If you are cutting the first panel, cut off the tongue side
- If you are cutting the last panel, cut off the groove (screw flange) side

When measuring the coverage needed, measure only the panel profile (exposed face), not the nailing flange. See the [Specifications](#) section of this document for more information about the exposed face dimensions of Trusscore Wall&CeilingBoard.

Remember – you need to allow for 1/4" of space at the end of the wall for expansion/contraction.

When installing the last panel of the wall, a putty knife can be helpful in bending the J Trim back to create enough space to get the panel into the trim.

## Cutouts

If holes are required for things like electrical boxes, lights, taps, etc., it is recommended to use a jigsaw or hole saw to cut out the shape, following the steps below.

1. Measure the location of the opening on the wall.
2. Mark the perimeter of your opening on the panel.
3. Drill a 1/2" hole in the corner of the required opening (Fig. 2).

Insert the blade into the hole and proceed to cut out along your marked lines.

If performing this cut after the panel has been installed, ensure the space behind the area to be cut is free of obstructions, electrical wires, plumbing or any other object.

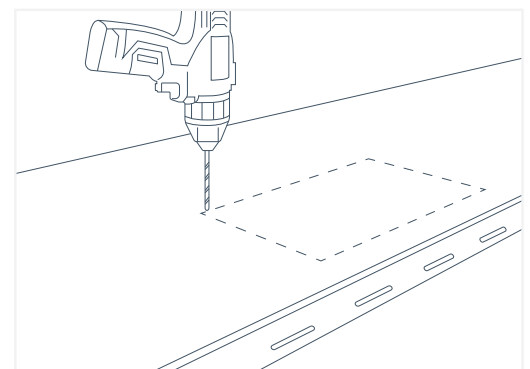

Fig. 2

## Fastening

Trusscore Wall&CeilingBoard is designed to be installed with screws. Use only corrosion-resistant (galvanized, stainless steel or aluminum) screws with a minimum head diameter of 3/8" (Fig. 3).

⚠ Do not use nails or staples to fasten panels.

### Recommended fasteners

- **Wood** – #10 X 1-1/4" Truss or Pancake Head screws
- **Concrete** – 3/16" x 1-1/4" Flathead screw (Tapcon)
- **Metal studs** – Make sure to use self-tapping screws instead of wood screws

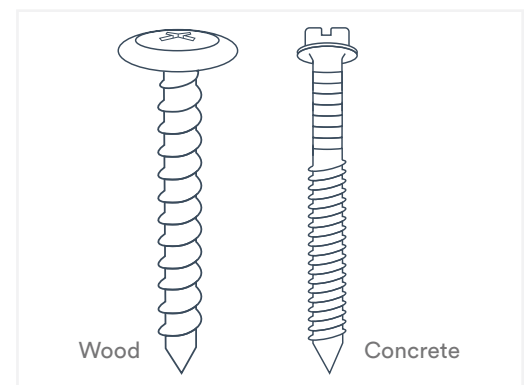

Fig. 3

If applying over drywall, screws should be 1-3/4" to 2" long. If furring strips or strapping are part of your installation, screws should be 2-1/2".

**⚠** Failure to follow fastening instructions may damage the panel and/or void the warranty.

### Fastening tips

- **Do not over-tighten fasteners**
- Allow a minimum of 1/16" (about the thickness of a dime) between the back of the fastener head and the screw flange (Fig. 4)
- Always fasten in the center of the screw flange slots; fastening at the end of the slots can cause the panels to buckle or distort (Fig. 5)
- Screws must be installed straight and level to allow for movement (Fig. 6)
- All panels must be allowed to slide freely after fastening to allow for expansion and contraction
- Fasteners should penetrate a minimum of 1" into solid backing
- Fasteners must be no more than 24" apart

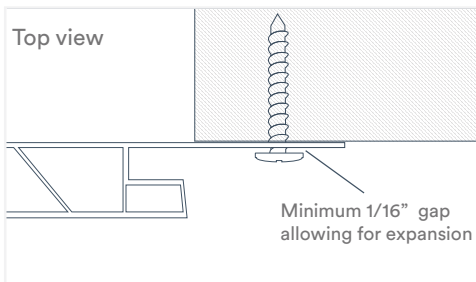

Fig. 4

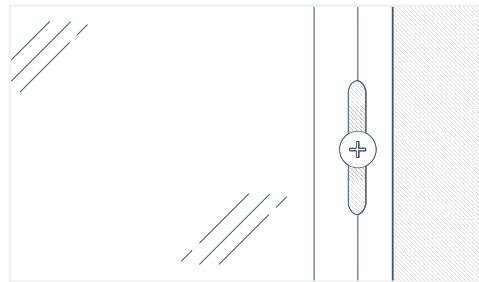

Fig. 5

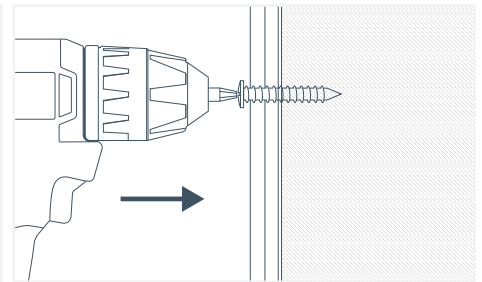

Fig. 6

### Panel Spacing

It is essential that a minimum of 1/4" clearance is left at the ends of all panels and trims to allow for expansion and contraction. For longer lengths (>20' long), allow 3/8" clearance.

For vertical panels or trims that sit flush on the bottom J Trim or Base Trim, a minimum of a 1/2" clearance must be left at the top of the panel (as all expansion will take place at the top of the panel).

### High-Moisture Environments

If you are installing Trusscore Wall&CeilingBoard in a high moisture environment such as a car wash, for example, the following guidelines must be followed:

- Apply a bead of silicone inside the grooved end of the panel prior to inserting the next panel
- If you are using J Trim at the bottom of your wall, you must drill drainage holes in the bottom of the J Trim per the guidelines in the [Trim application](#) section of this document

### Use of Silicone Sealant

We recommend that a one-part, neutral cure silicone sealant is used to seal all corners, around all fixtures, and to repair small holes. The sealant color should be off-white to match the panels.

## Radiant Heat

All sources of radiant heat must be shielded and located with a minimum of 24” clearance between it and Trusscore Wall&CeilingBoard. Consult the manufacturer of any heater for further guidelines regarding any necessary shielding and clearances before installing.

## Epoxy Floors

When installing Wall&CeilingBoard in a location that will receive an epoxy floor, the epoxy cannot be sprayed onto the Trusscore Wall&CeilingBoard.

## CFIA, USDA & FDA Approved Installations

Trusscore Wall&CeilingBoard panels are fully compliant with the requirements set out by the CFIA, USDA and FDA for areas where food is prepared. In these applications, the following guidelines must be followed.

- The product is strictly for use on non-food contact surfaces
- All joints are to be sealed with an acceptable flexible caulking compound to provide a smooth, flush, and impervious joint

In Canada, MONO® SILICONE MAX™ Premium Kitchen & Bath Sealant can be used for this application. In the USA, the product is branded as DAP Commercial Kitchen 100% Silicone Sealant. Both meet FDA Reg. 21, CFR 177.2600 and are certified to NSF/ANSI Standard #51.

## Planning & Preparation

### Acclimatizing Your Product

Trusscore Wall&CeilingBoard must sit in the location where it will be installed for a minimum of 24 hours before installation. This will minimize the amount of expansion or contraction that occurs after the product is installed and ensure the best possible installation.

We recommend that you loosen or remove any packaging material that may restrain the product while acclimatizing.

### Planning Your Installation

- Check surfaces for straightness and install furring strips or strapping where necessary; make sure that all vapor barriers, etc are installed to code prior to Trusscore Wall&CeilingBoard being installed
- Trusscore Wall&CeilingBoard should be installed perpendicular to ceiling joists or roof trusses; when additional strapping must be installed, 1”x4” or 2”x4” furring strips or strapping should be the minimum that is installed; if installing parallel, joists must be 16” on-center
- If furring strips or strapping are required, it should be installed perpendicular to the framing members at 24” on-center
- Install wood blocking (short pieces of lumber for added support/coverage) around all openings to properly support trims
- If you’re suspending lights or other items, install adequate backing at each location as required; never mount items directly to Trusscore (continued on the next page)

- Do not begin installation until the building is fully enclosed, heating/cooling equipment is in operation and any residual moisture from construction has been removed

## Installation Order

If Trusscore Wall&CeilingBoard is being installed on both the ceiling and walls of a project, it should always be installed on the ceiling first.

## Ceiling Installation

- Begin by installing the necessary trims on the perimeter of the ceiling and around any openings. Guidelines for trim installation can be found in the [Trim Applications](#) section of this document.
- Cut the length of the first panel for the first course. Position the panel so the screw flange is pointing away from the wall (Fig. 7). Ensure the panel is parallel to the outside wall before fastening.
- Leave a 1/8" gap between the tongue side of the panel and the adjoining trim. Fasten a minimum of once every 24" with the appropriate recommended fasteners. Remember to leave 1/4" of clearance at both ends of the panels for expansion and contraction (Fig. 8). Remember not to over tighten your fasteners.
- If your ceiling is longer than your panel lengths, the panels must be joined in the middle using the H Channel Snap-In Kit (Fig. 9). Refer to the Joining Panels portion of the [Trim Applications](#) section of this document for details.
- With the first panel row installed, the rest of the ceiling panels can be installed. The tongue of the second panel will be inserted into the groove of the first panel. Press panels firmly together during installation to ensure a proper connection. Once the two panels are firmly interconnected, the most recently added panel can be fastened.
- Periodically check your installation to ensure the panels continue to be installed in straight, even rows. To do this, measure the distance from the wall to the edge of your panels at both ends of the panel (Fig. 10). If both measurements are identical, the installation is adequately aligned. If the measurements are uneven, you will need to correct the positioning of your board.
- The final panel may need to be trimmed to fit. Refer to the [Ripping Panels](#) section for details on how to do this.

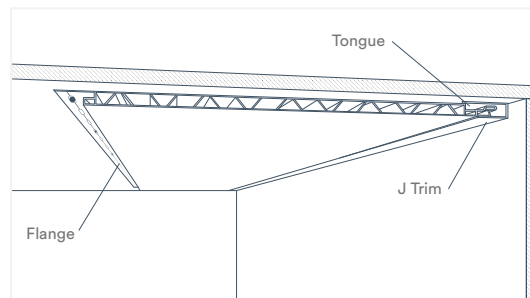

Fig. 7

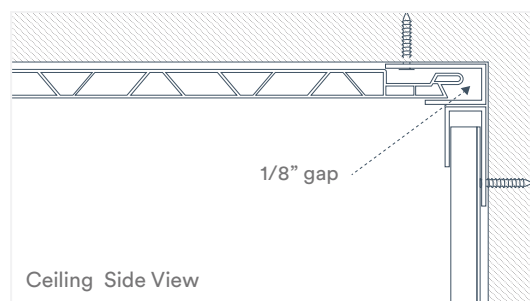

Fig. 8

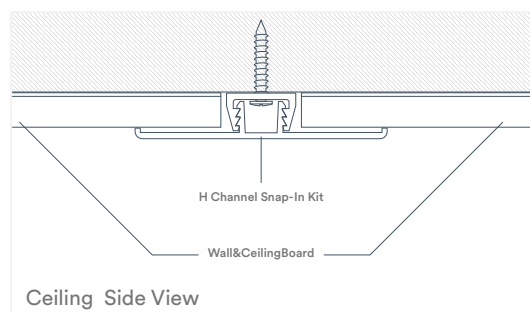

Fig. 9

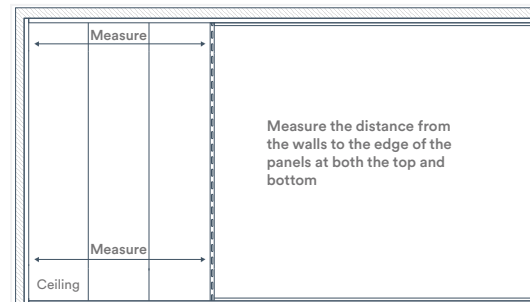

Fig. 10

## Drywall Grid Ceiling Installation

Wall&CeilingBoard may be installed as part of a drop ceiling application using drywall grid, which is designed for applications where materials will be fastened by screw. If Trusscore Wall&CeilingBoard will be installed in this manner, please consider the following:

- Install the panels perpendicular to the drywall grid
- Plan your installation in advance so trims can be installed directly into the grid; main beams are preferable, but cross tees can also be added to support these trims
- Panels must be fastened into the grid from below to ensure a waterproof installation; they cannot be dropped into the grid in this application
- The grid should be arranged so the panels are fastened a minimum of 24” on-center
- A #12 x 3/4” pan head stainless steel screw is suggested for fastening

## Wall Installation

### Vertical Panels

1. Begin by installing the Base Trim or J Trim along the bottom of your wall. Guidelines for trim installation can be found in the [Trim Applications](#) section of this document.
2. If you are using J Trim for your corners, they should be installed before your panels. If you are using inside cove corner, they should be installed after the adjoining wall panels. Then, install perimeter trims required around openings like doors or windows. .
3. At the top of your wall, you can now install J Trim or Inside Cove Corner.
4. Cut the length of the first panel for the first course. Place the panel with the tongue side in the corner trim and the groove (screw flange) side facing away from the wall (Fig. 11). Ensure the panel is parallel to the outside wall before fastening. Leave a 1/8” gap between the tongue side of the panel and the adjoining trim. Fasten a minimum of once every 24” with the recommended fasteners
5. Remember to leave 1/4” of clearance at both ends of the panels for expansion and contraction. Remember not to over tighten your fasteners.
6. With the first panel row installed, you’re the remaining wall panels can be installed. The tongue of the second panel will be inserted into the groove of the first panel. Press panels firmly together during installation to ensure a proper connection. Once the two panels are firmly interconnected, the most recently added panel can be fastened.

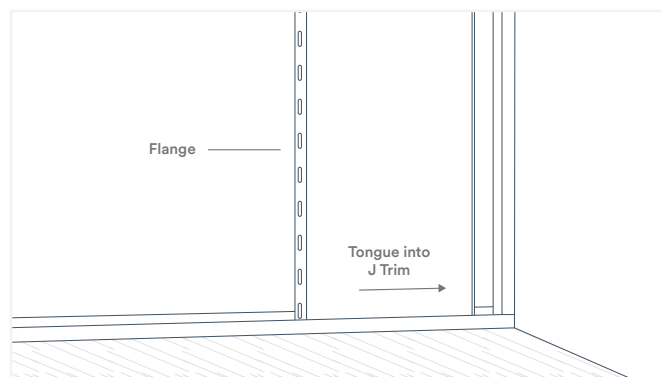

Fig. 11

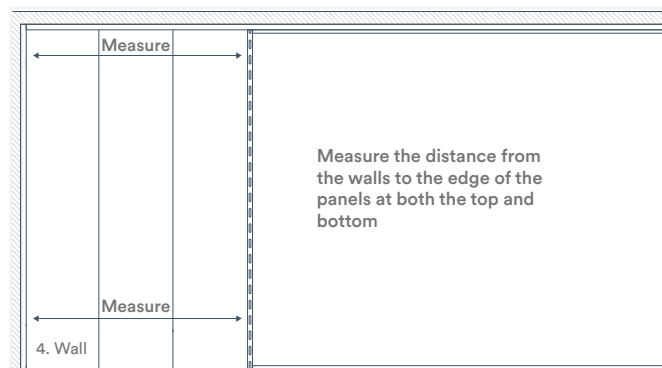

Fig. 12



7. Check your installation periodically to ensure the panels continue to be installed in straight, even rows. To do this, measure the distance from the wall to the edge of your panels at both the top and bottom of the panel (Fig. 12). If both measurements are identical, the installation is adequately aligned. If the measurements are uneven, you will need to correct the positioning of your board.
8. Your last panel may need to be trimmed to fit. Refer to the [Ripping Panels](#) section for details on how to do this.

## Horizontal Panels

Installation with horizontal panels is almost identical to vertical panels, with a few special considerations.

- The tongue side of the panel should be installed facing towards the floor, the groove (screw flange) side facing towards the ceiling (Fig. 13)
- As you add panels, insert silicone into the panel joint to ensure no water will pool in that connection
- If your wall is longer than your panels, join the consecutive panels with an H Channel Snap-In kit (Fig. 14)

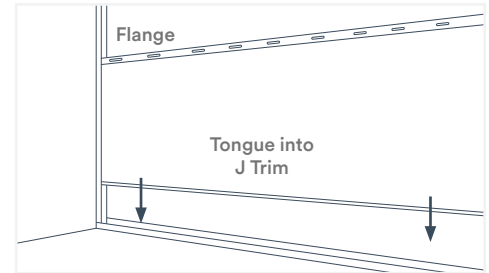

Fig. 13

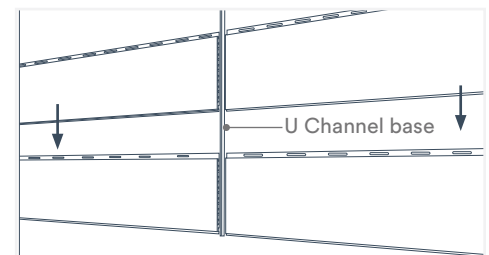
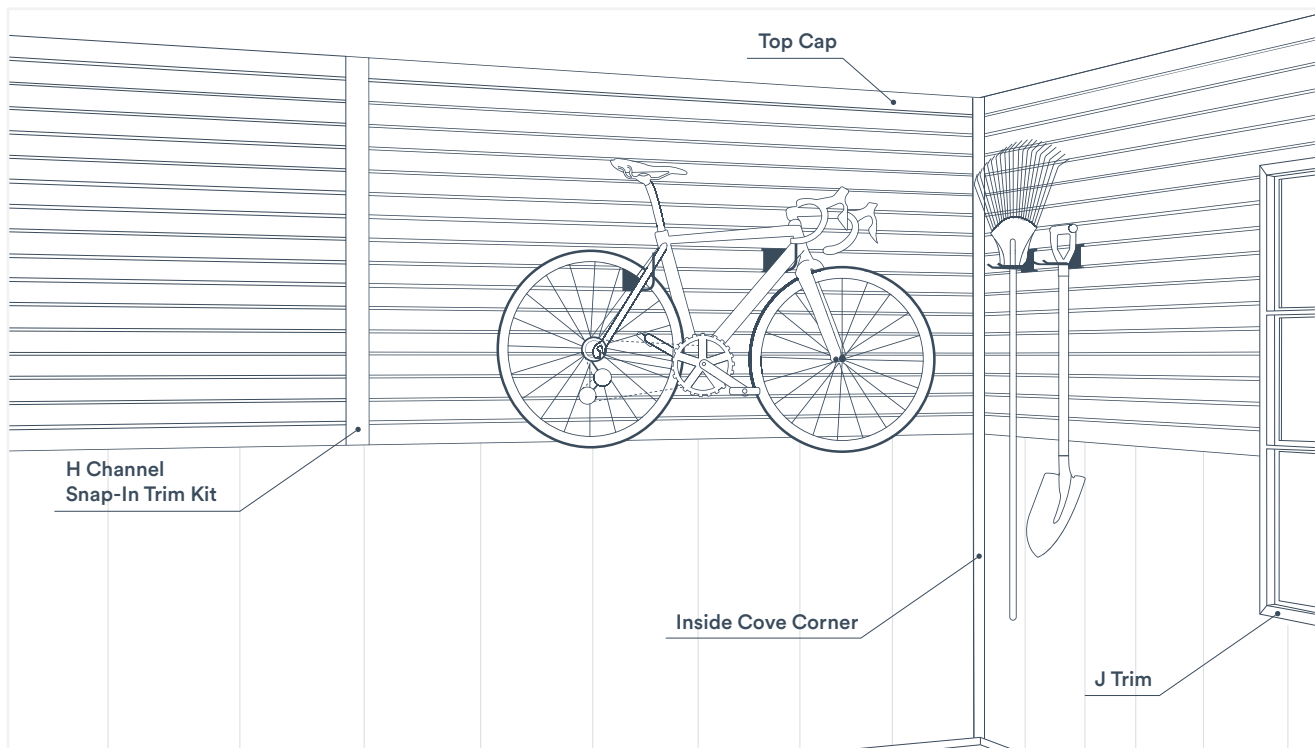

Fig. 14

## Integrating Trusscore SlatWall with Trusscore Wall&CeilingBoard

Trusscore SlatWall integrates seamlessly with Trusscore Wall&CeilingBoard. This section will walk you through the installation process of integrating the two products in your project.

For even more detailed instructions and considerations regarding the installation of Trusscore SlatWall, please visit the [Trusscore SlatWall Installation Guide](#).



Planning and preparing your desired installation space are necessary first steps. Please refer to the [Planning & Preparation](#) section of this installation guide.

### Placement and Layout of Installation Area

1. Refer to the image below for the recommended installation layout (Fig. 15) and appropriate spacing measurements (Fig. 16). It is critical to leave adequate spacing between Wall&CeilingBoard panels and the SlatWall panel area for the H Channel Snap-In Trim which will serve as the transition trim between the two products. Suggested spacing is the same for both horizontal and vertical Trusscore Wall&CeilingBoard installation orientations.

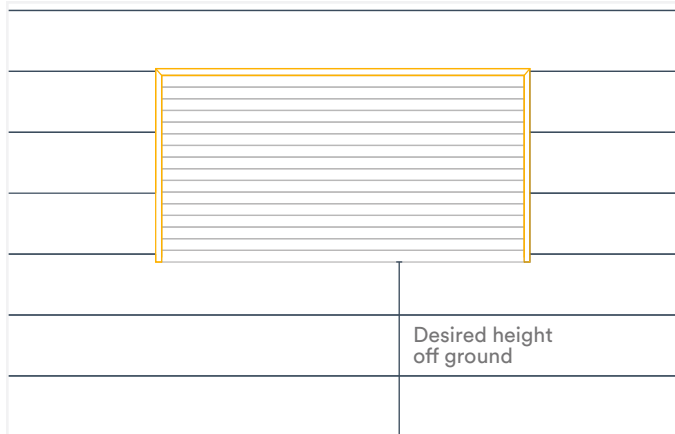

Fig. 15

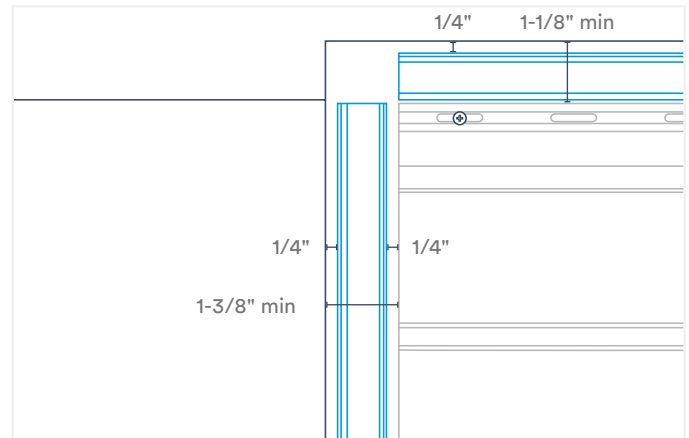

Fig. 16

■ Trusscore Wall&CeilingBoard   ■ Trusscore SlatWall   ■ H Channel Snap-In Trim   ■ U Channel Base

2. Inside the SlatWall installation area, locate and mark each wall stud using a stud finder (Fig. 17). Use a level and a pencil to mark each stud from the top to the bottom of your installation area, ensuring each line is plumb (Fig. 18).

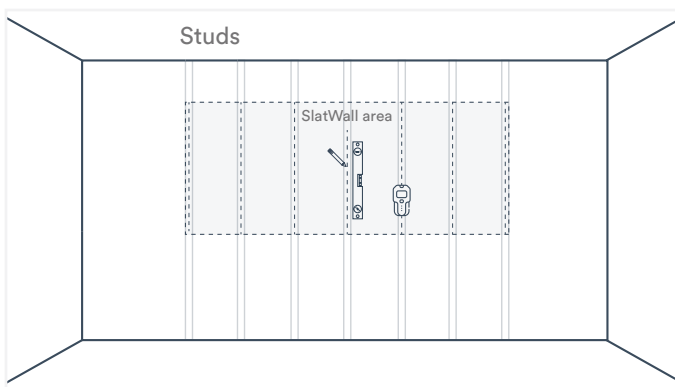

Fig. 17

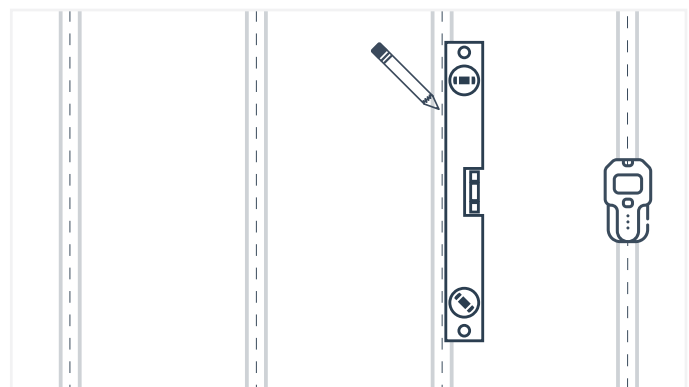

Fig. 18

**⚠** Trusscore SlatWall panels must start fastened to a stud, and finish fastened to a stud. Each SlatWall panel must also be fastened to studs every 16" on-center minimum in order to support up to 75 lbs per square foot. If stud intervals are greater than 16", the installation of blocking between studs may be required to provide sufficient support to the SlatWall panels, trim and any adjacent Trusscore Wall&CeilingBoard panels if applicable.

3. Install your Trusscore Wall&CeilingBoard panels as previously detailed, leaving an opening for your SlatWall installation as determined by the spacing guidance provided in Step 1 (Fig. 19).

Please see the [Wall Installation](#) section of this installation guide for detailed instructions on how to install Trusscore Wall&CeilingBoard on walls.

### Bottom Connection

Trusscore SlatWall is designed to easily install directly above vertically and horizontally oriented Trusscore Wall&CeilingBoard panels.

When installing the SlatWall panels in a **vertical** Wall&CeilingBoard install, rest the bottom lip on the back of the SlatWall panel directly on top of the Wall&CeilingBoard panel below it (Fig. 20). Once in place, use a level to ensure it is horizontally level before fastening (Fig. 21).

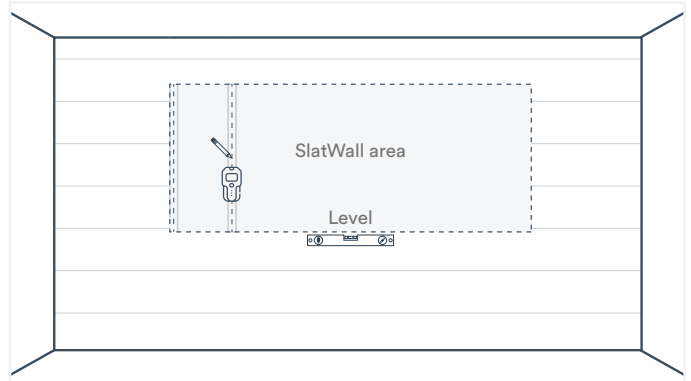

Fig. 19

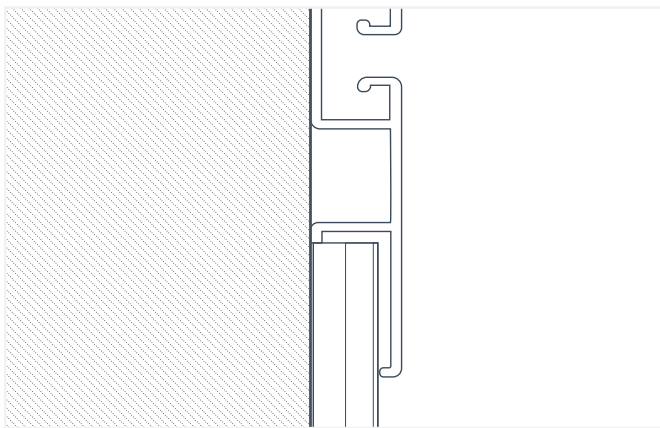

Fig. 20

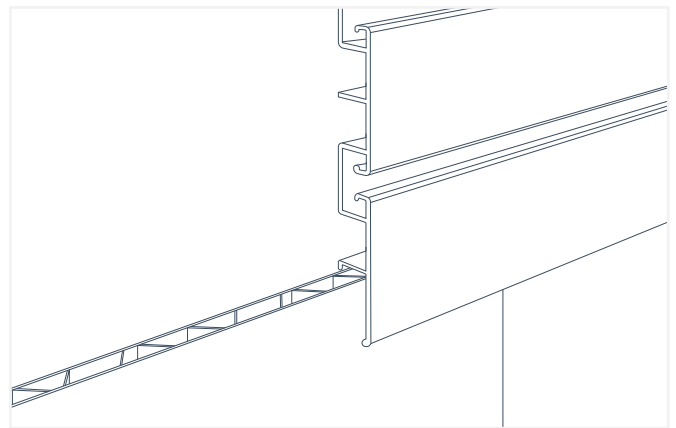

Fig. 21

When installing the SlatWall panels in a horizontal Wall&CeilingBoard install, there are two possible installation configurations depending on the intended height of the bottom SlatWall panel from the ground.

- The distance from the floor to the bottom of the first SlatWall panel is an even increment of 16" (the width of the exposed face of Wall&CeilingBoard panels). The resulting connection between SlatWall and Wall&CeilingBoard is shown below (Fig. 22).
- If the desired distance from the floor to the bottom of the first SlatWall panel is not an even multiple of 16", the Wall&CeilingBoard panel closest to the floor should be ripped to an appropriate width to achieve the desired SlatWall height (Fig. 23). The resulting connection between SlatWall and Wall&CeilingBoard is shown below.

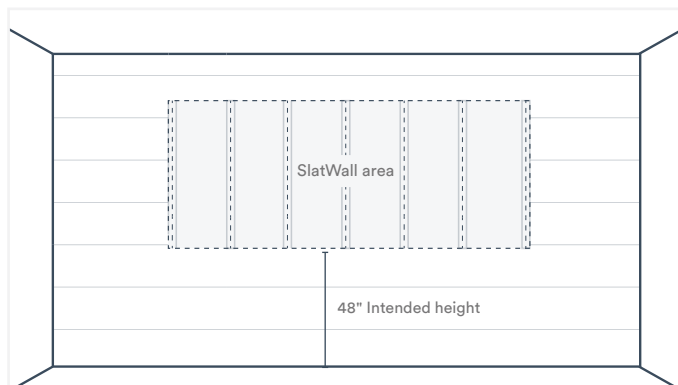

Fig. 22

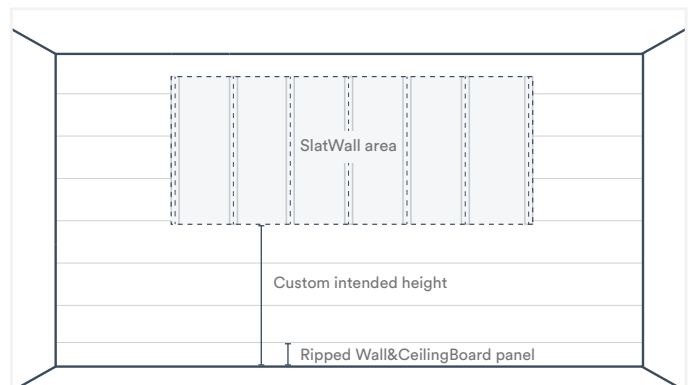

Fig. 23

Please reference the [Ripping Panels](#) section of this installation guide for further instruction on performing rip cuts on Trusscore Wall&CeilingBoard panels.

1. Prior to installing the first (bottom) panel of SlatWall, use a level to verify that the Wall&CeilingBoard panel you're connecting with has been cut/installed in a level, straight line.
2. If your installation is in a space with strong air movement, place a bead of silicone inside the bottom lip of the SlatWall panel where it meets the Wall&CeilingBoard panel(s) (Fig. 24). This ensures the panel will remain fixed in place. This step is optional.
3. Fasten the SlatWall panel to the wall through the screw flange and into each available stud.

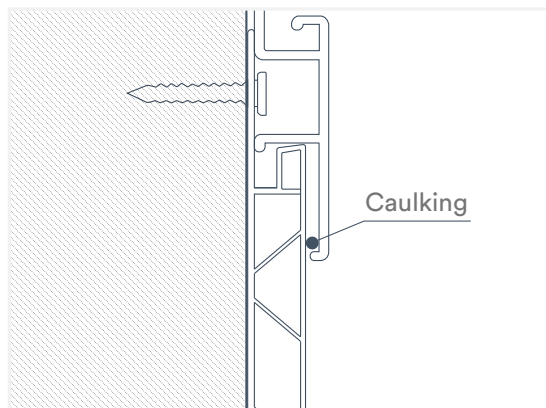

Fig. 24

**!** Do not overtighten the screws as this will disrupt the installation of subsequent panels.

### Installing the Remaining Trusscore SlatWall Panels

Starting from the bottom, proceed with installing the remaining SlatWall panels.

1. Place a panel on top of the previously installed panel, aligning the ends of both panels (Fig. 25).
2. Starting at one end and moving to the other, apply gentle downward pressure (towards the floor) to interlock the panel with the previously installed panel below. You will feel and hear a “snap” when the panels have properly interlocked together (Fig. 26).
3. Fasten the panel you just placed into position by drilling a fastener (screw) through the slotted screw flanges into each of the studs you marked in an earlier step.
4. Repeat steps 1-3 above step for all remaining panels.

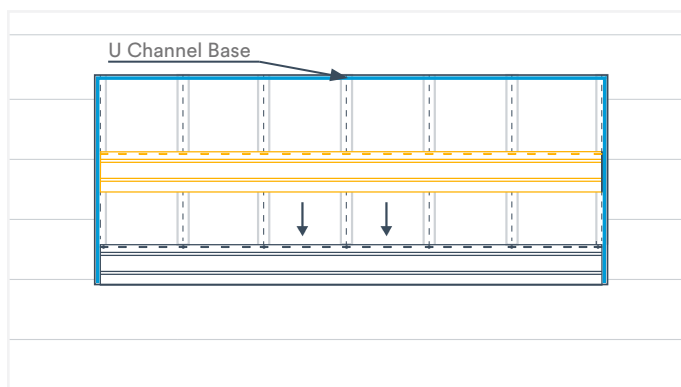

Fig. 25

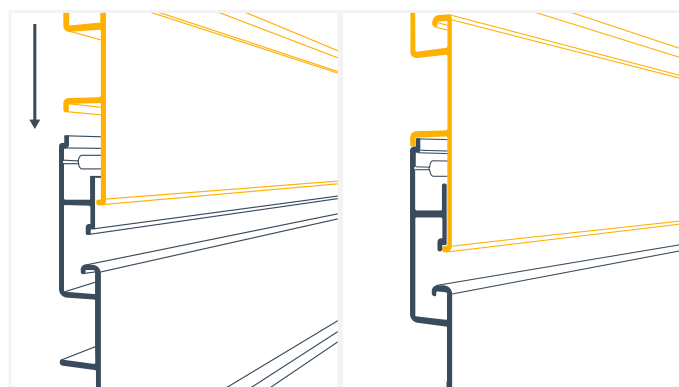

Fig. 26

### Side Connection

An **H Channel Snap-In Trim Kit** accommodates the transition between the ends of SlatWall panels and any adjacent Trusscore Wall&CeilingBoard panels.

There are two components to an H Channel Snap-In Trim kit:

- H Channel Snap-In
- U Channel base

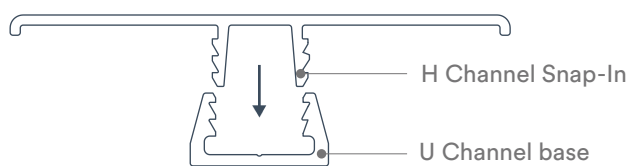

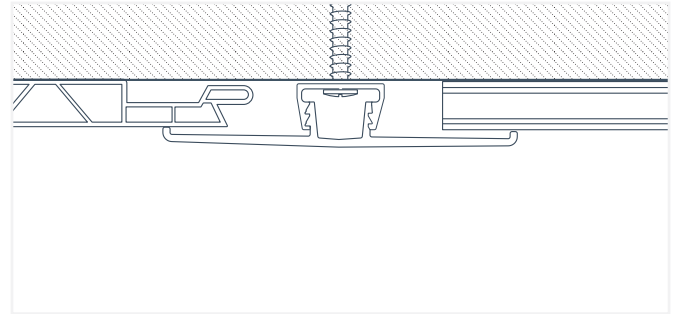
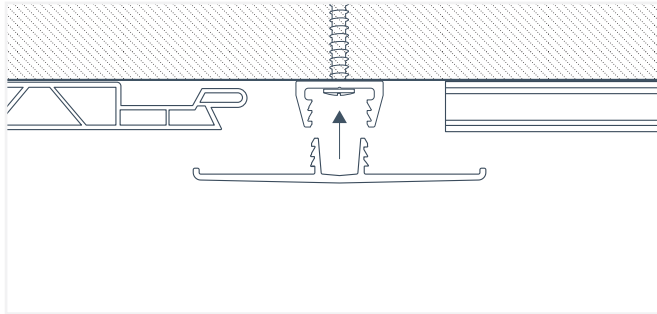
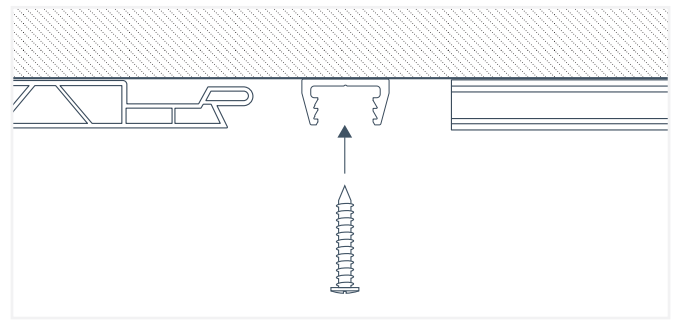
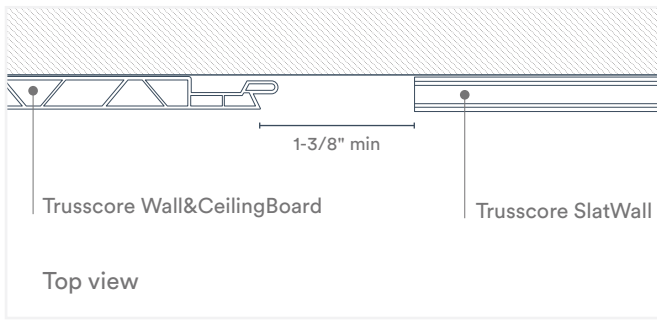

**!** Ensure the U Channel Base is removed from the H Channel Snap-In Trim before starting.

1. Using a power saw, cut the end of an H Channel Snap-In Trim at a 45° (mitered) angle. For best results, place the finished face of the trim upwards to perform the cut.
2. Place the H Channel Snap-In Trim up to your installation area and make a mark where it meets the bottom edge of the bottommost SlatWall panel. Cut the H Channel Snap-In Trim square at this mark.
3. Measure and mark 1-1/4" inwards from the bottom edge (end) of the H Channel Snap-In Trim. At the mark, make a vertical snip in both grooved standoffs using tin snips (Fig. 27).
4. Using the tip of the tin snips, remove the remaining stand-off material between your vertical snip and the bottom edge (end) of the trim (Fig. 28). The remaining material should be small enough to allow the H Channel Snap-In piece to sit flush overtop of the Trusscore Wall&CeilingBoard panel below it, without obstruction.

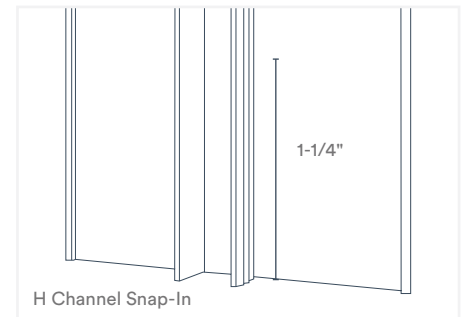

Fig. 27

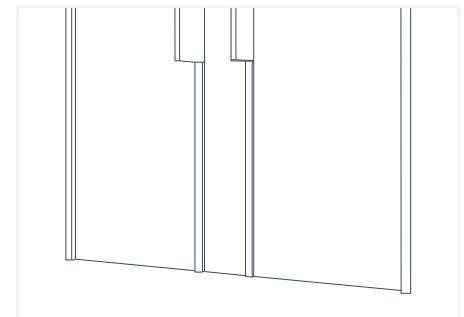
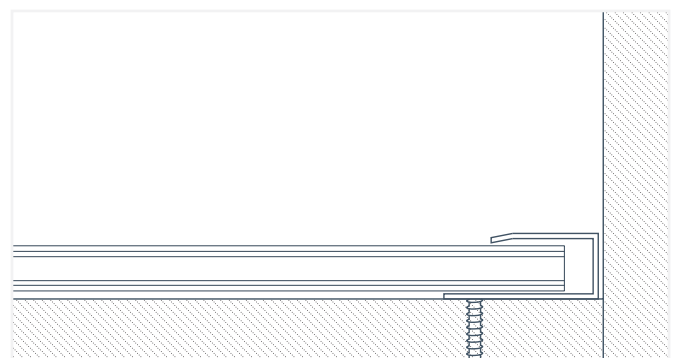
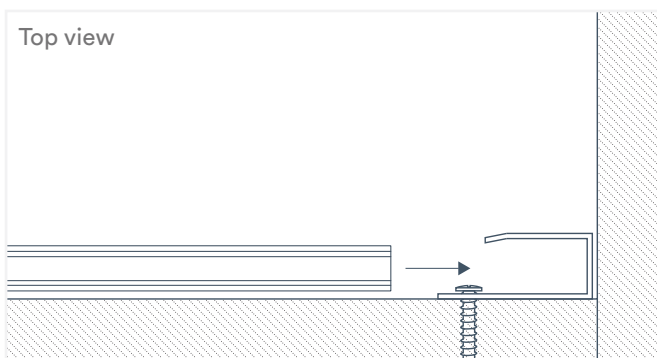

Fig. 28

### Installing SlatWall in the Corner of a Room

#### 3/4" J Trim



## Inside Cove Corner Trim

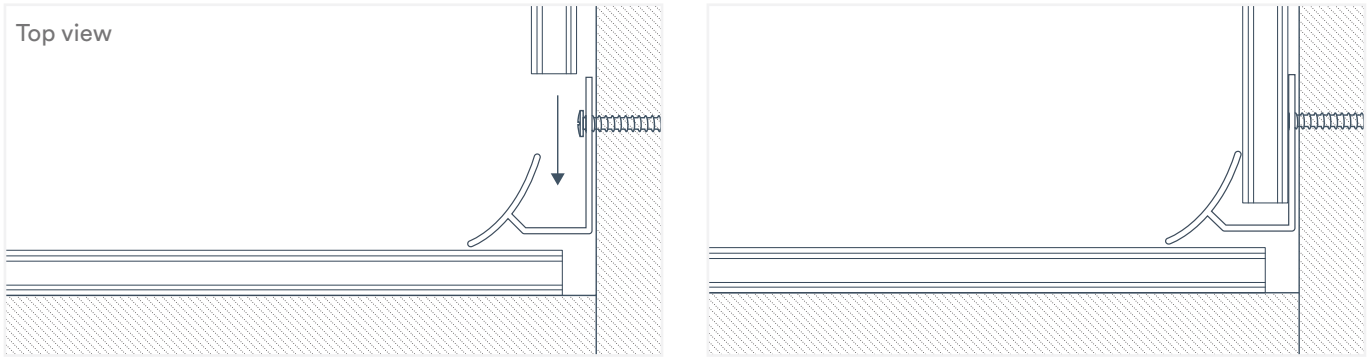

## Top Connection

An **H Channel Snap-In Trim** accommodates the transition between the ends of SlatWall panels and any adjacent Trusscore Wall&CeilingBoard panels.

There are two components to an H Channel Snap-In Trim kit:

- H Channel Snap-In
- U Channel base

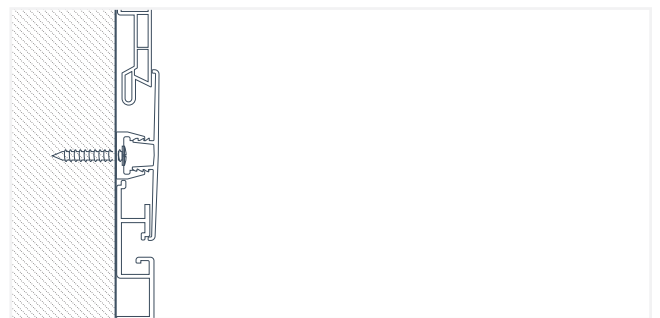
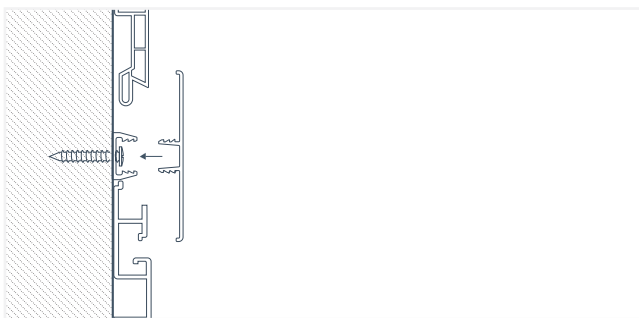
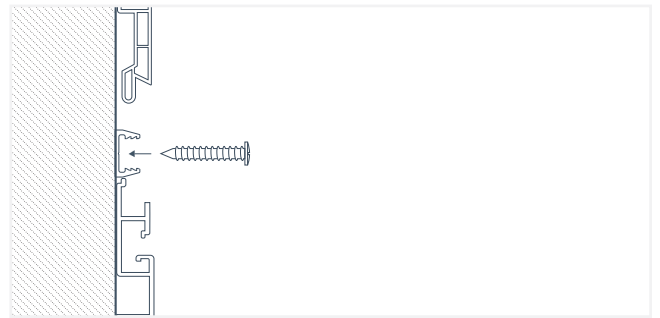
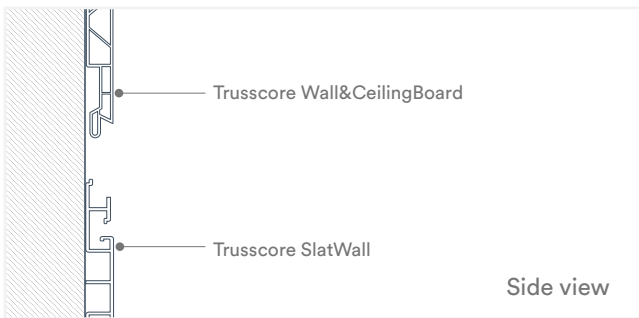
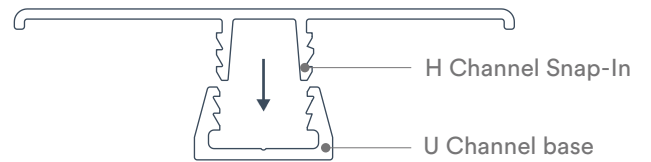

1. Position the U Channel base to ensure that when the H Channel Snap-In is inserted in place, the lip at the outer edge of the H Channel Snap-In aligns with the top row groove of the SlatWall panel (Fig. 29). When fastening the U Channel base to the wall, leave a gap of approximately 0.25" (1/4") between the U Channel base and the Wall&CeilingBoard installed above the SlatWall area.

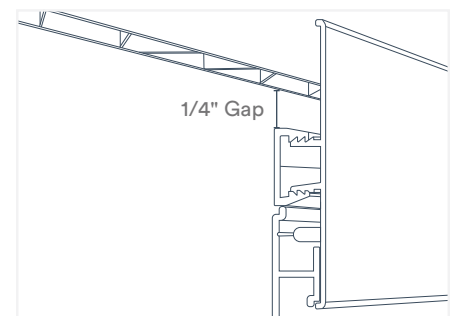

Fig. 29

# Trim Applications

## Installation Tips

- Tin snips are the safest and easiest tool to use when cutting trims; for a cleaner cut, avoid closing the blades at the end of a stroke
- Trims should be screwed to the substrate at least once every 24” and at least 4” from the end of the panel
- If an area requires more than 10’ of continuous trim, the trims should be butted tightly together with silicone sealant placed between the two pieces
- To create a water-tight corner at door and window openings, insert a small bead of silicone caulking on channel opening of trim pieces before installing panels

## Inside Corners

### One J Trim

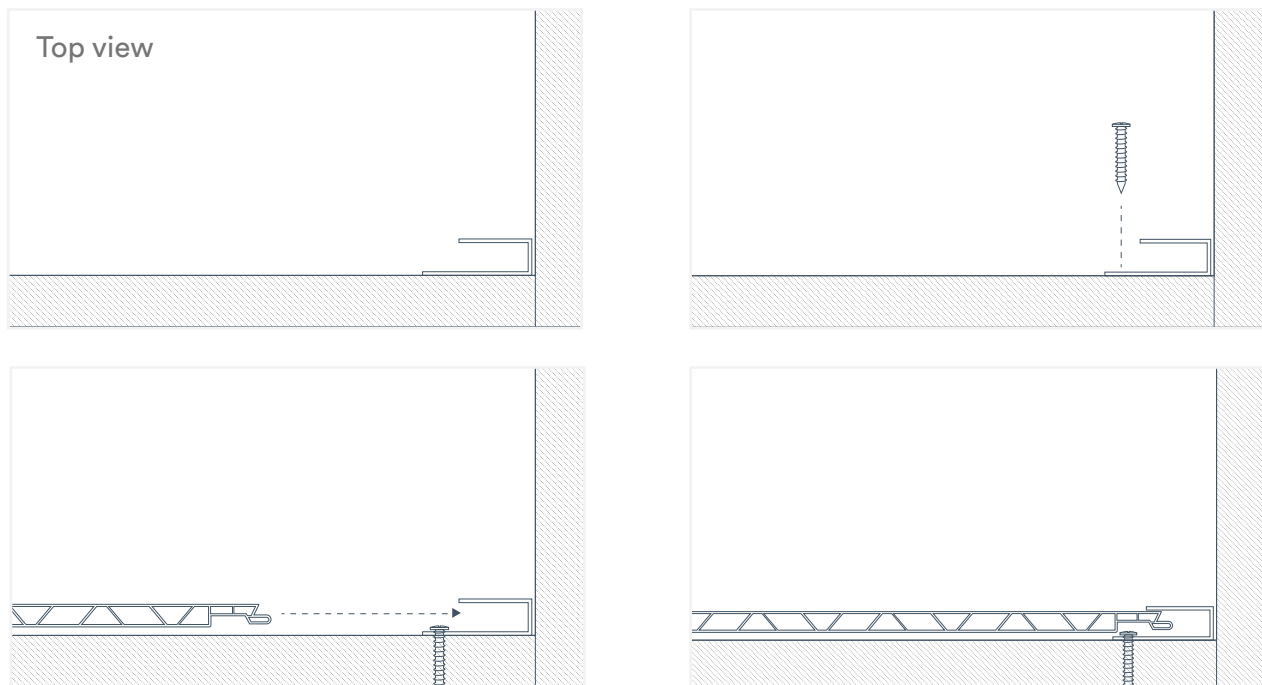

## Two J Trims

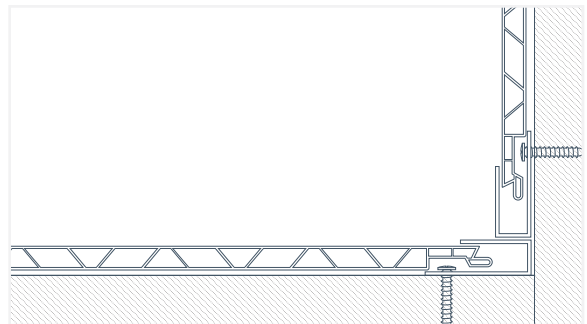
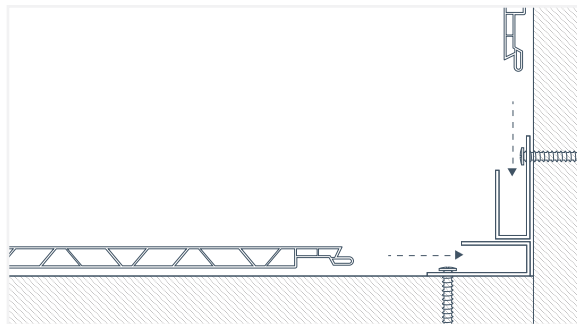
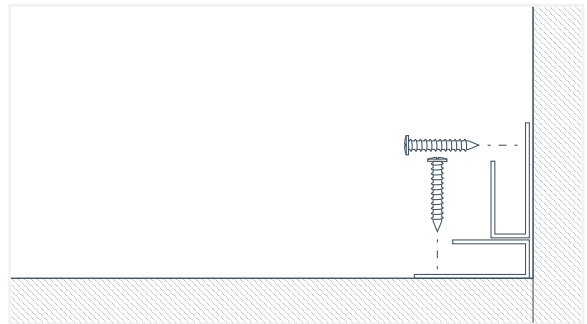
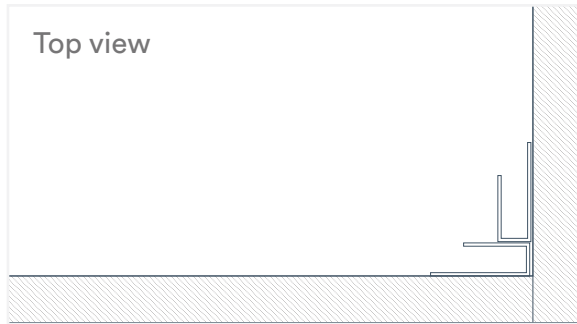

## Inside Cove Corner

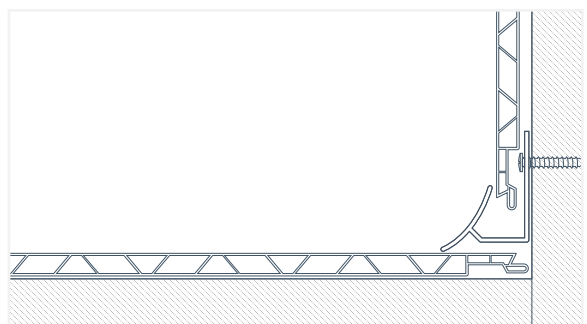
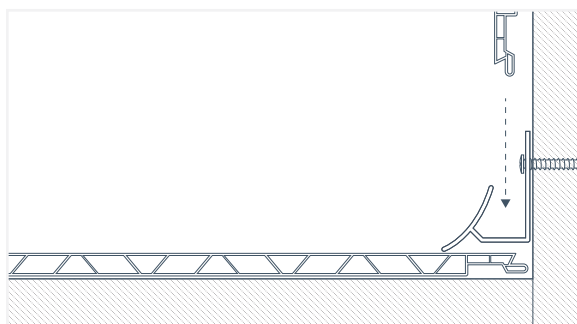
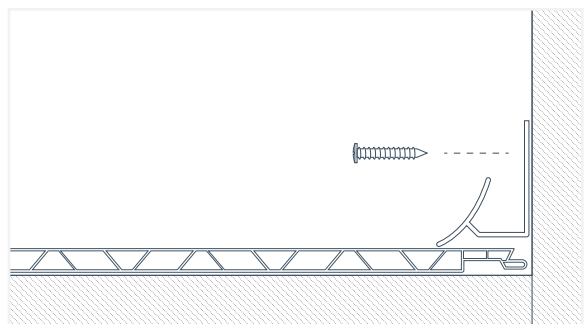
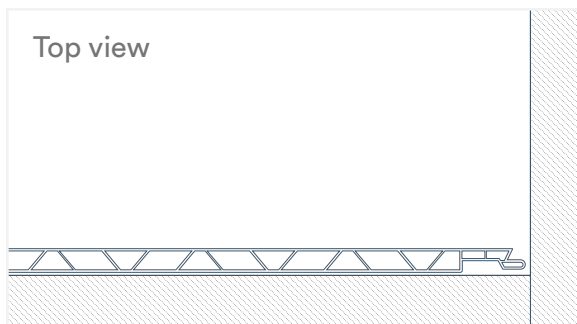

For information on the required spacing between Wall&CeilingBoard panels and trims, refer to [page 7](#) for ceilings and [page 8](#) for walls.



## Outside Corners

### Outside Corner Rounded

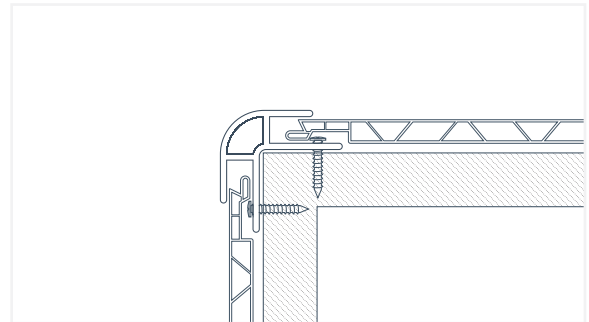
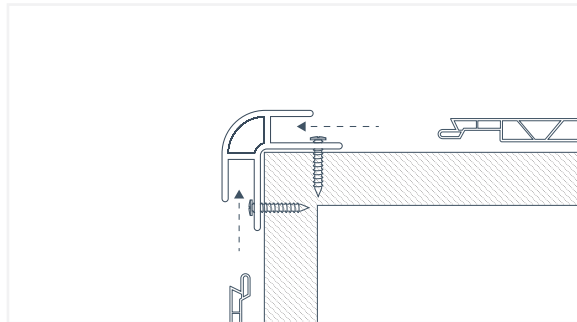
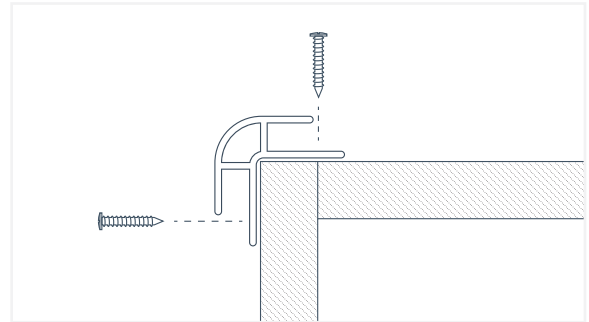
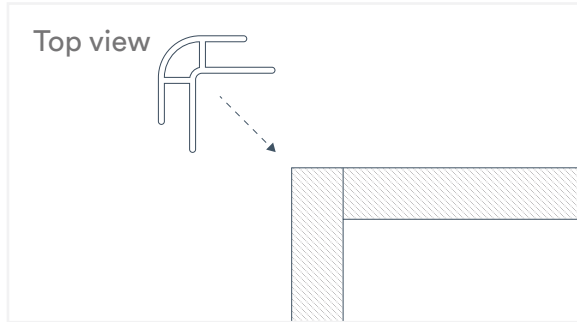

### Outside Corner Square

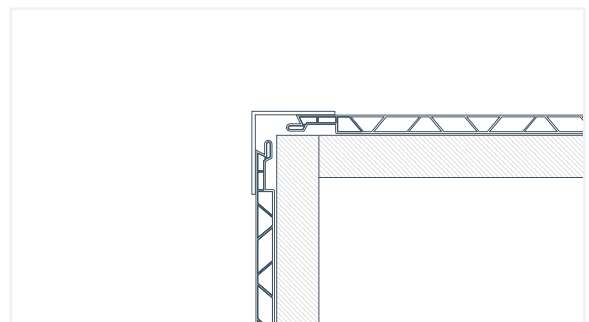
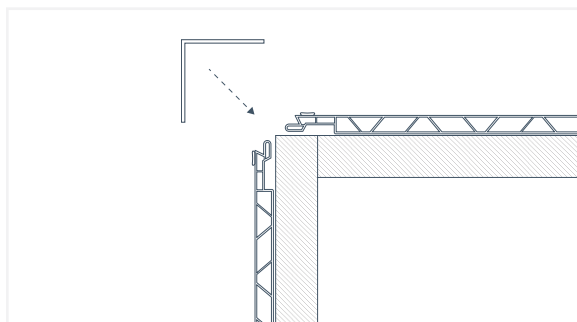
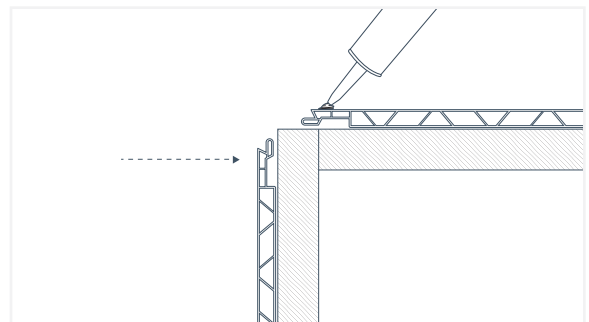
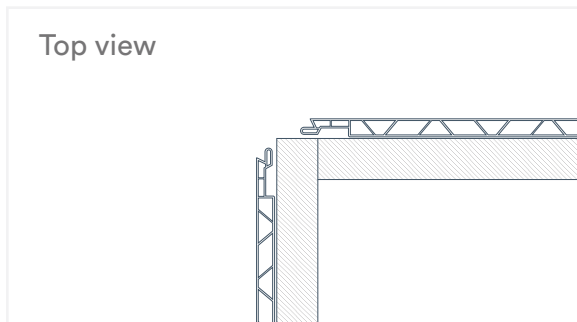

## Bottom of Wall

### Base Trim

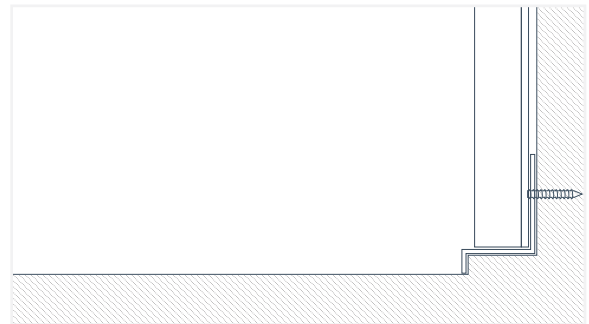
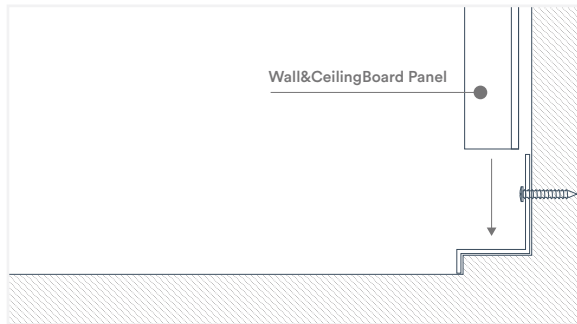
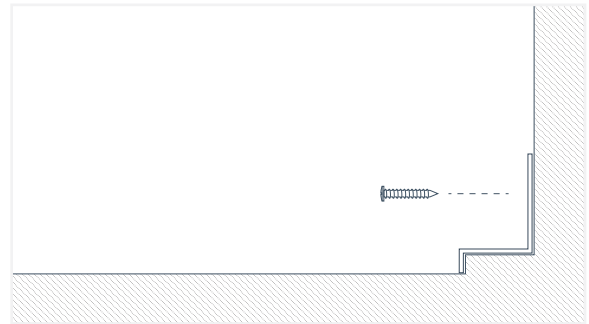
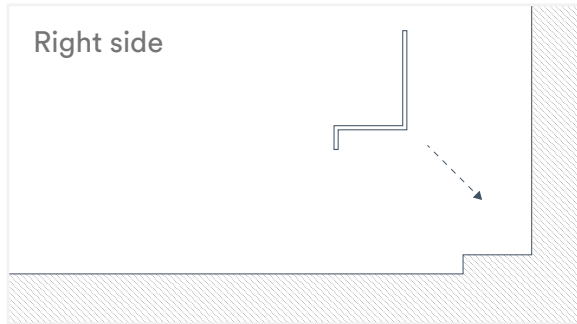

Do not use base trim on sloped floors.

### J Trim

To ensure drainage, drill 1/4" diameter holes into the bottom of the J Trim before installing it on the wall. Holes should be placed 16" on center.

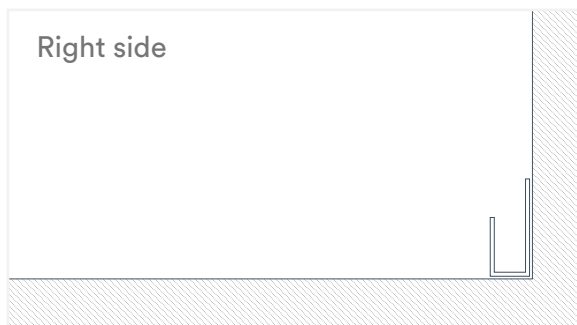
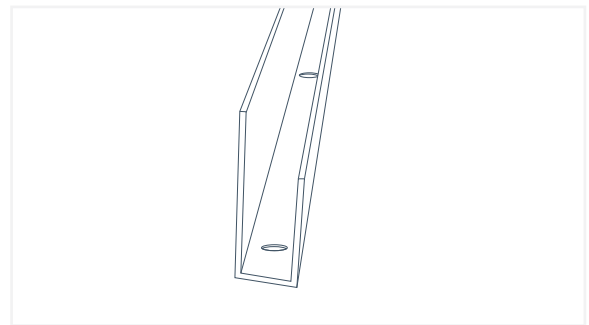
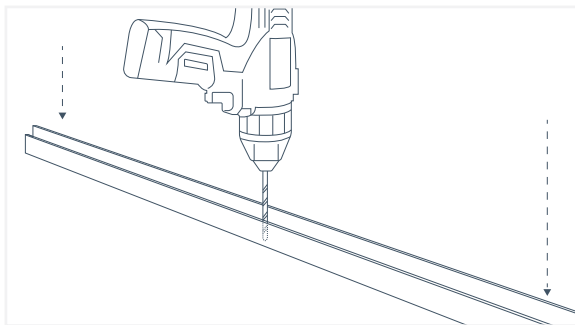

For information on the required spacing between Wall&CeilingBoard panels and trims, refer to [page 7](#) for ceilings and [page 8](#) for walls.

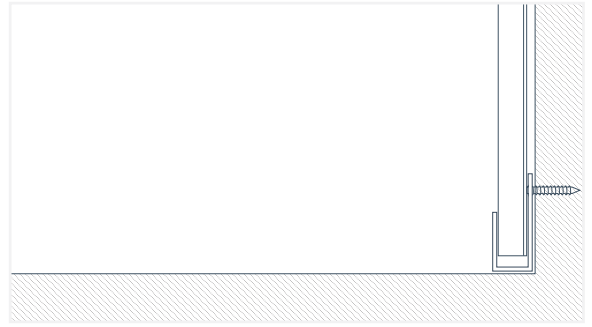
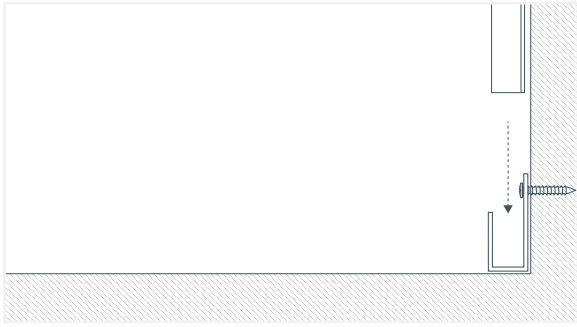

## Top of Wall

### J Trim

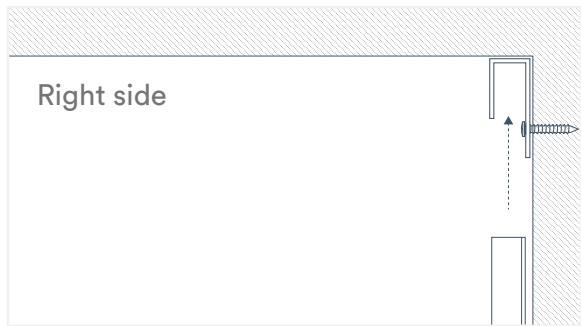

## Inside Cove Corner

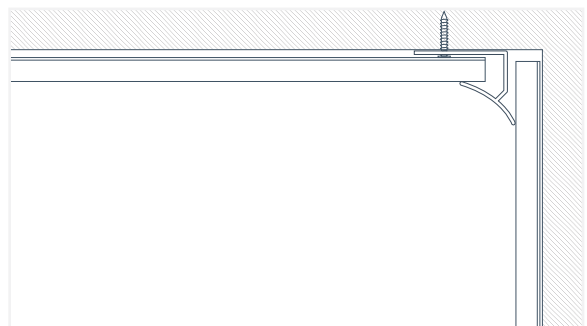
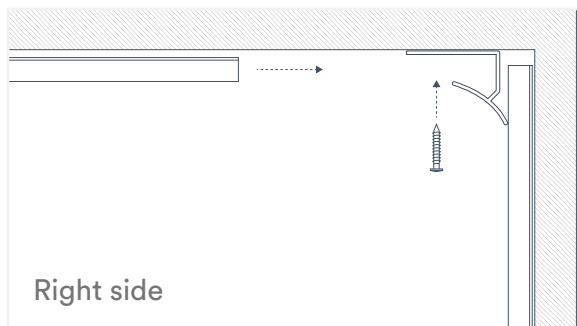

## Ceiling Perimeter

### J Trim

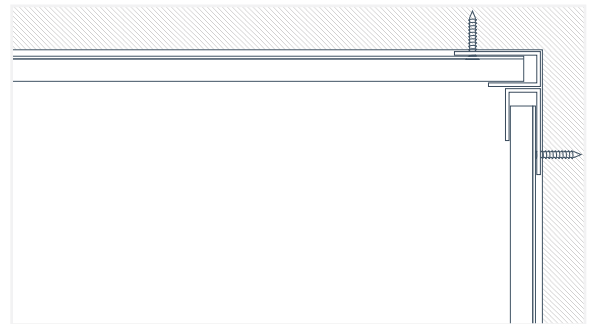

### Inside Cove Corner

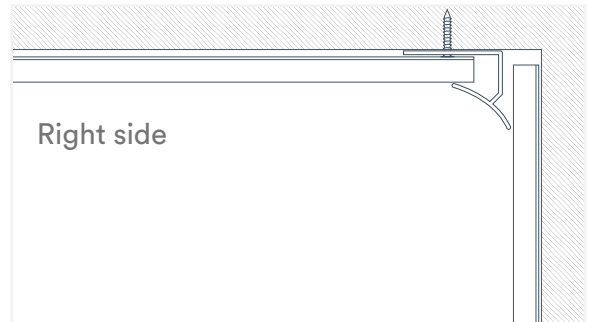
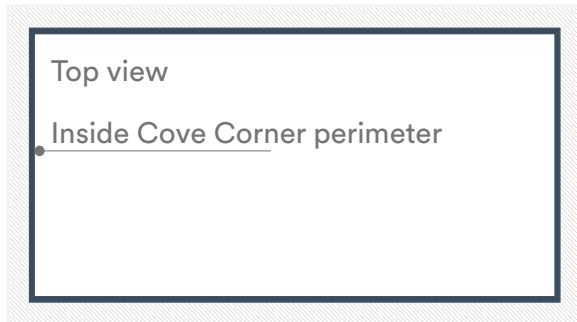

## Panel Joints

### H Channel Snap-In Kit

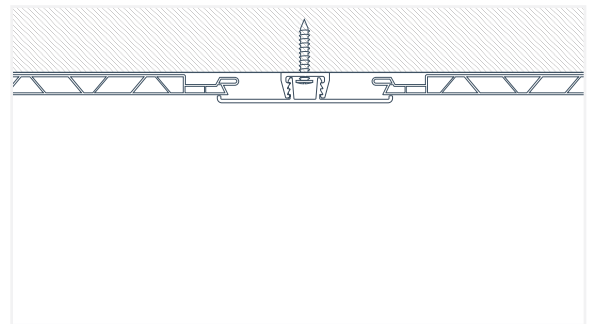
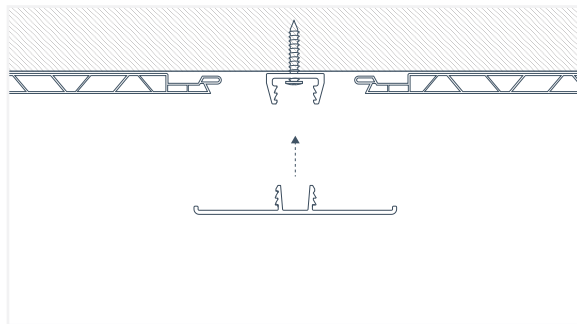
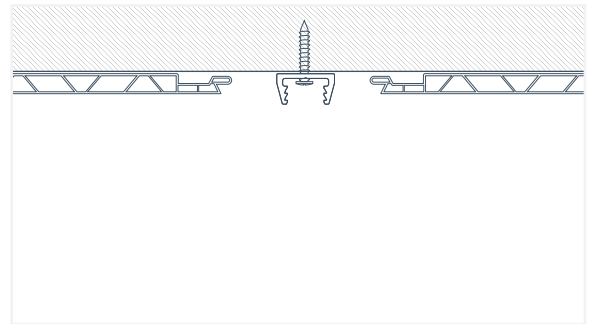
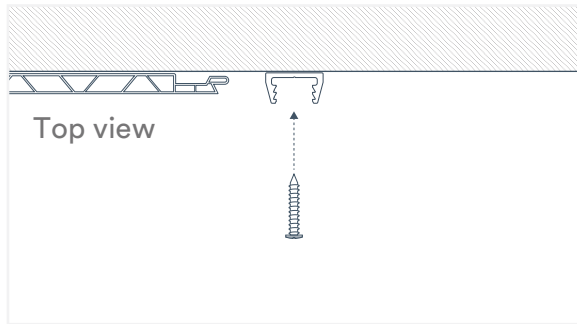

## Window & Door Openings

### J Trim

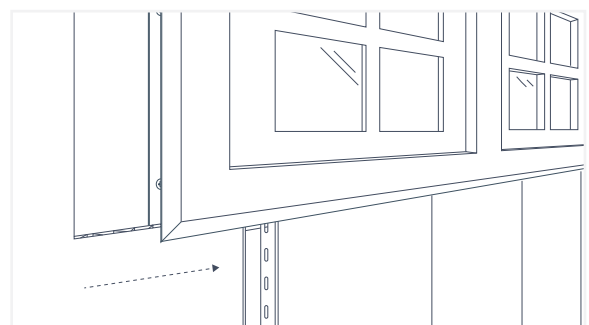
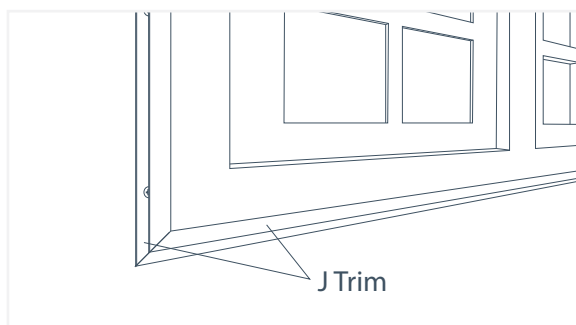
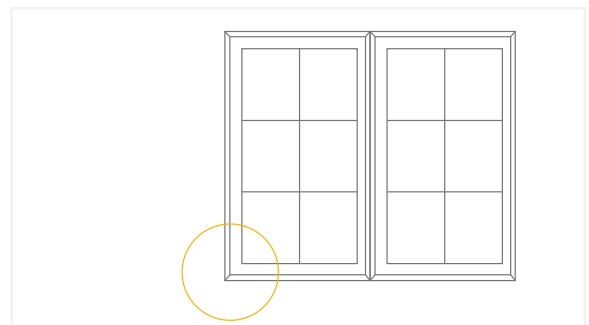
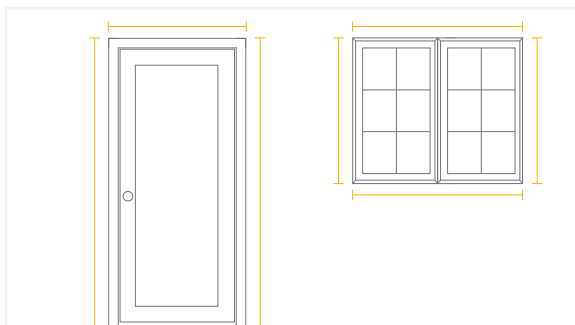

## Outside Corner

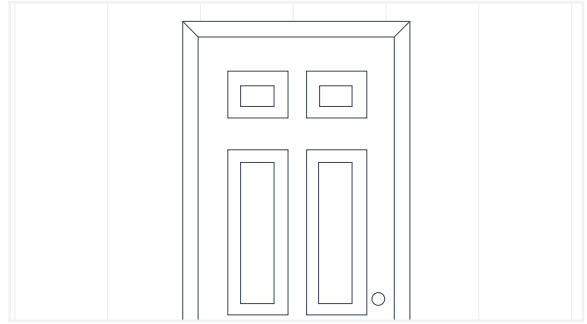
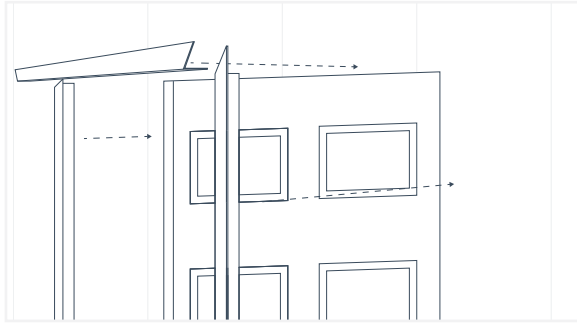
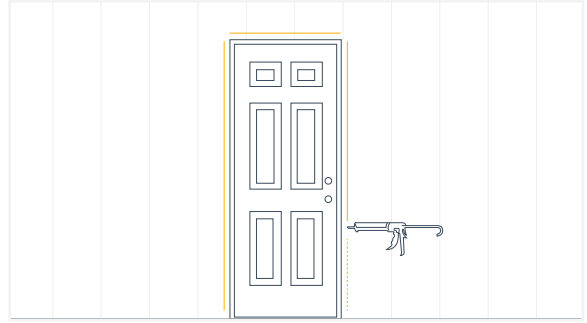
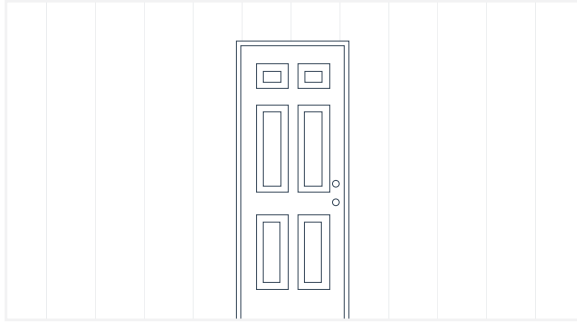

## How to Replace a Damaged Panel After Installation

In the unlikely situation where a panel becomes damaged after it has been installed, follow the steps below to remove and replace it:

1. Set the depth of a handheld circular saw to 1/2" — the thickness of a Wall&CeilingBoard panel.
2. Using the saw, cut through the center of the damaged panel, parallel to the panel joints (Fig. 30).
3. The side of the panel with the tongue should slide easily out of the adjacent panel (Fig. 31).
4. On the groove side that remains, make another cut beside the panel joint (Fig. 32).
5. Now, tilt the next panel out of the way and remove the screws from your panel (Fig. 33).
6. Insert the U Channel base piece (from the H Channel Snap-In Kit) along the groove side of the panel (Fig. 34).
7. Cut your replacement panel to fit between the existing panel joint and the U Channel base (Fig. 35)

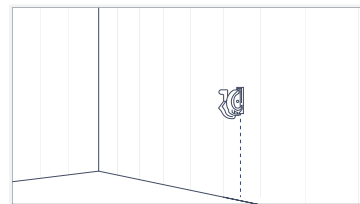

Fig. 30

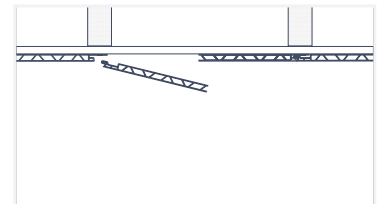

Fig. 31

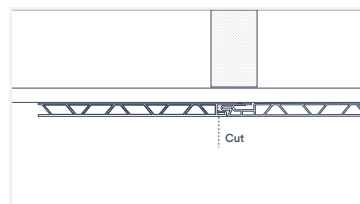

Fig. 32

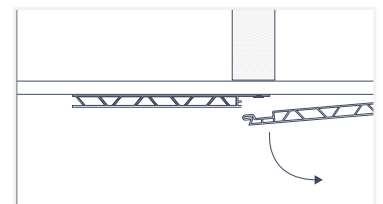

Fig. 33

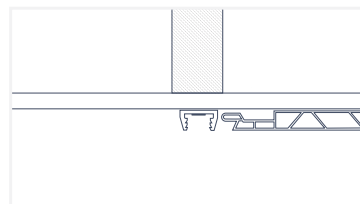

Fig. 34

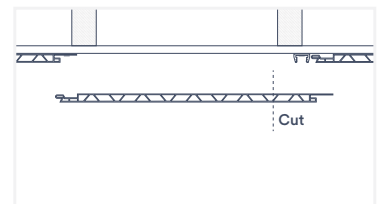

Fig. 35

8. Insert the replacement panel onto the wall, screwing directly into the cut edge of the panel (Fig. 36).
9. Snap the H Channel cap onto the U base to complete the installation (Fig. 37).

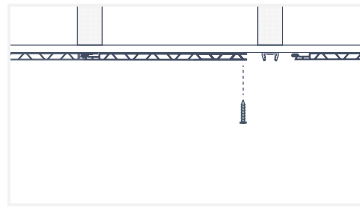

Fig. 36

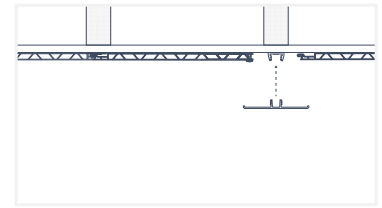
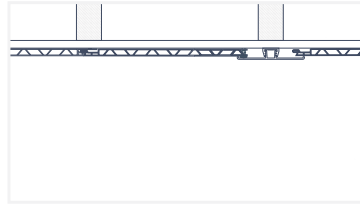

Fig. 37



## Cleaning

Here are some guidelines to help you handle any level of dirt your product encounters.

### Day-to-Day Cleaning

To remove common dirt and maintain your Trusscore product's beautiful appearance, wash using a sponge or soft cloth and a mild cleaning solution.

Abrasive cleaning pads/cloths should not be used as they could scratch or alter the surface of the product.

If the dirt is difficult to remove, wipe clean with a solution of:

- 1/3 cup laundry detergent (e.g. Tide®)
- 2/3 cup tri-sodium phosphate (e.g. TSP®)
- 3.79 L (1 Gallon) of water

Swiffer® Dusters™ are very helpful in removing dust from Trusscore Wall&CeilingBoard.

Mr. Clean® Magic Erasers™ can be used to remove marks on Trusscore Wall&Ceilingboard.

### Pressure Washing

When hand cleaning doesn't get the job done, pressure washers may be used with mild soap and a sponge or soft cloth, provided the guidelines below are followed:

- Power washing nozzle should be at least 4-6 ft away from the wall
- Use a small-to mid-size power washer with less than 3,000 psi
- Use a wide spray nozzle angle (40° or greater is preferred) to distribute the water pressure across the wall

## Disclaimers

The manufacturer is not responsible for problems related to expansion due to temperature fluctuations. If wide temperature fluctuations exist in the area of the Trusscore installation, allow for expansion and contraction gaps in moldings and perimeter. Before installation, Trusscore Wall&CeilingBoards and trims should be acclimatized to minimize expansion and contraction issues.

As part of our focus on continuous innovation, Trusscore leverages advancements in material science to improve the performance and environmental impact of our products. Through the use of zero wastewater production processes, incorporation of recycled material in our products, and commitment to using raw materials with low environmental impact we are developing more sustainable building products.

Our drive to continually develop better-looking, better-performing, and more sustainable products can result in minor changes to the color and texture of our products when compared to previously manufactured products. Therefore, install products of the same package and/or pallet when completing your project to ensure the best possible results to minimize any minor variations.

## Specifications

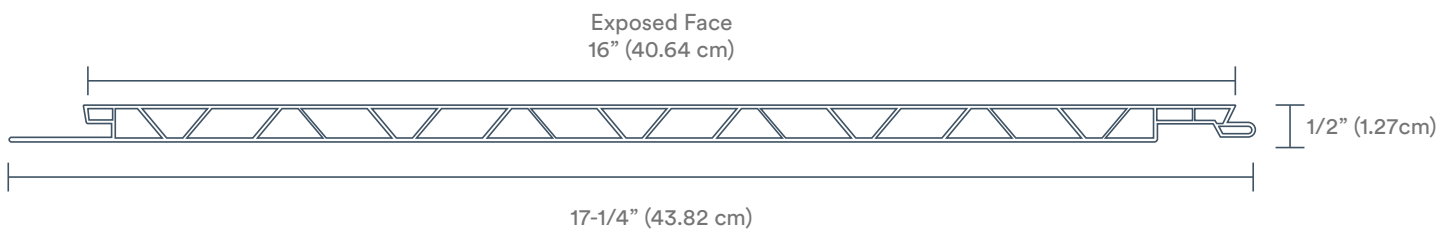
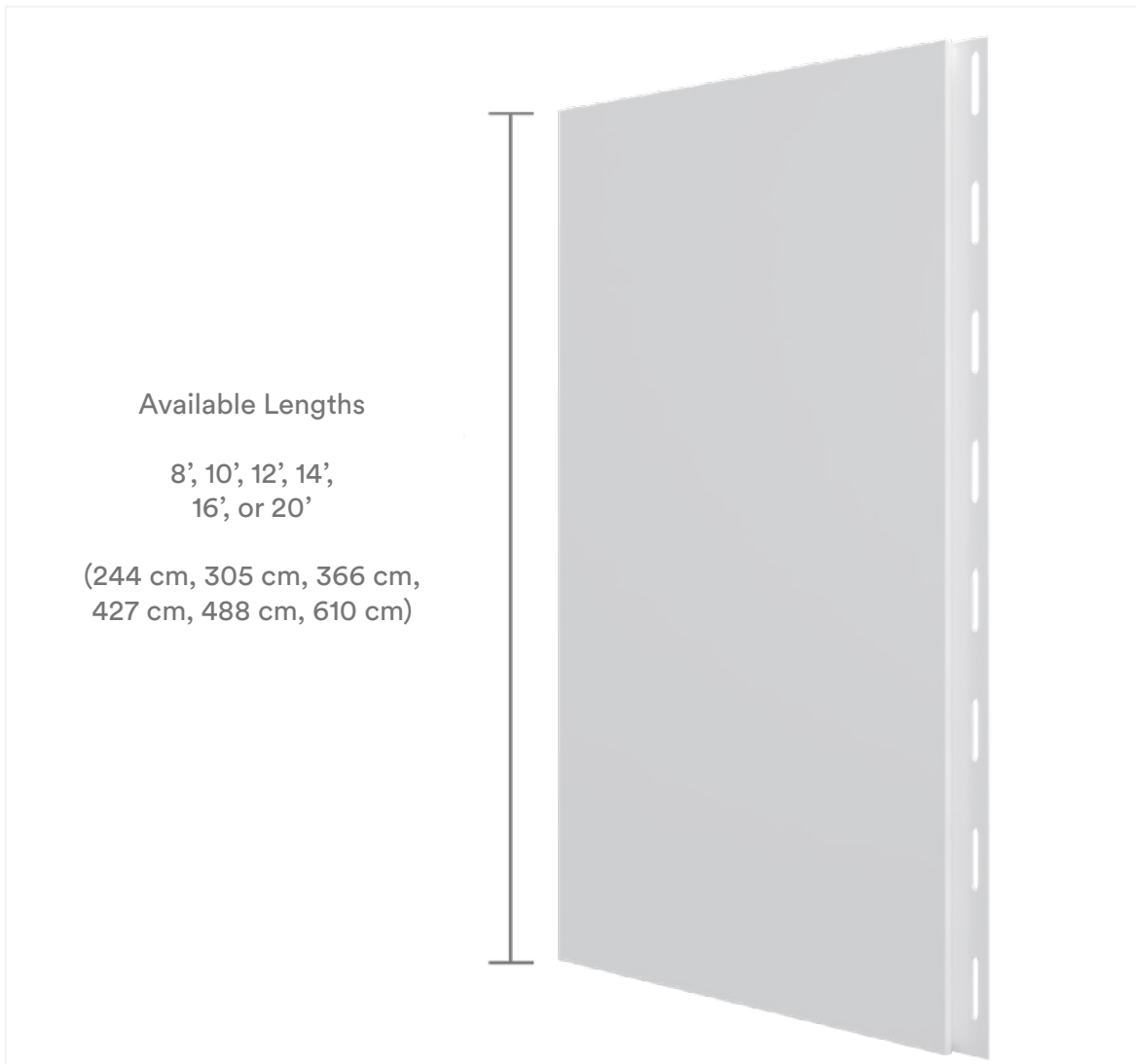



# Trim Dimensions

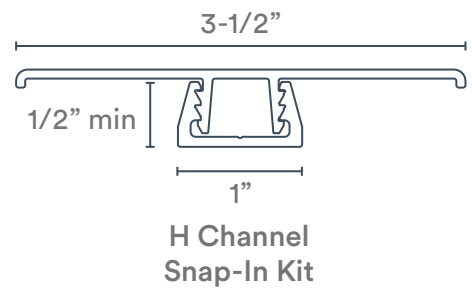
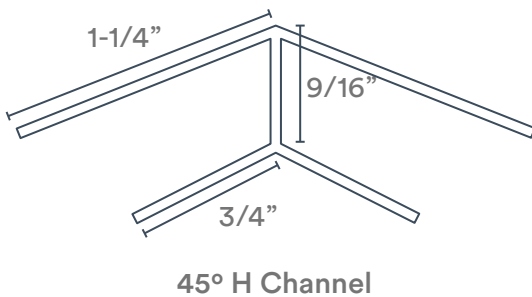
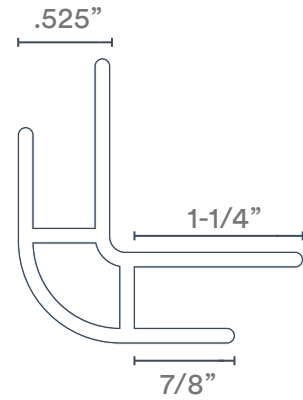
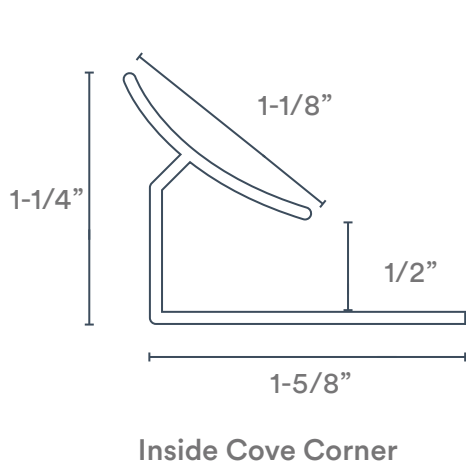
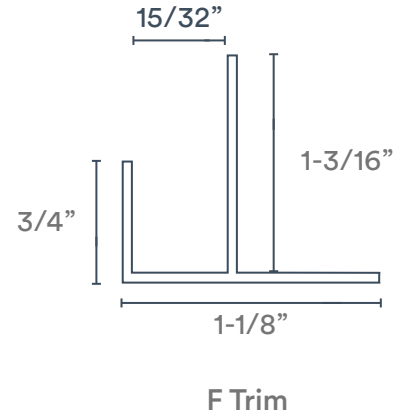
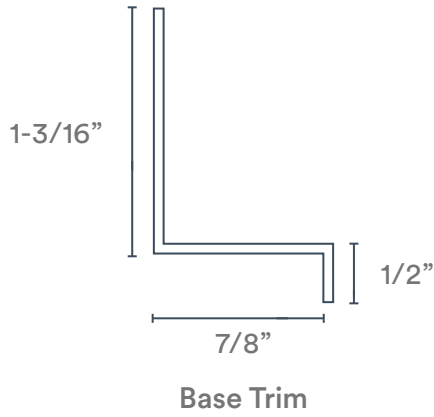
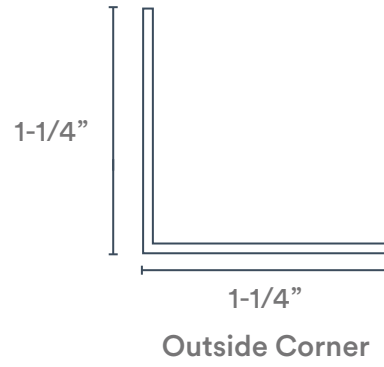
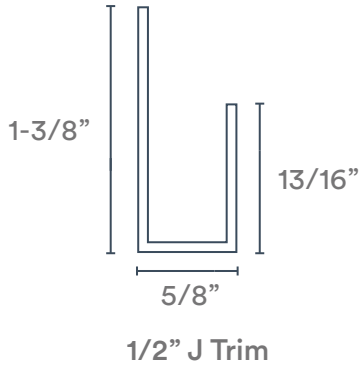



[trusscore.com](https://trusscore.com)

Learn more about Trusscore  
[trusscore.com](https://trusscore.com) | [hello@trusscore.com](mailto:hello@trusscore.com) | 1.888.418.4679

Copyright © 2021 Trusscore Inc. Trusscore is a trademark of Trusscore Inc. All other trademarks are the property of their respective owners.  
Specifications are subject to change. T-IG101-004 09/2021

